

2.4 JERSEY KERB A - CLASS

Front Elevation View

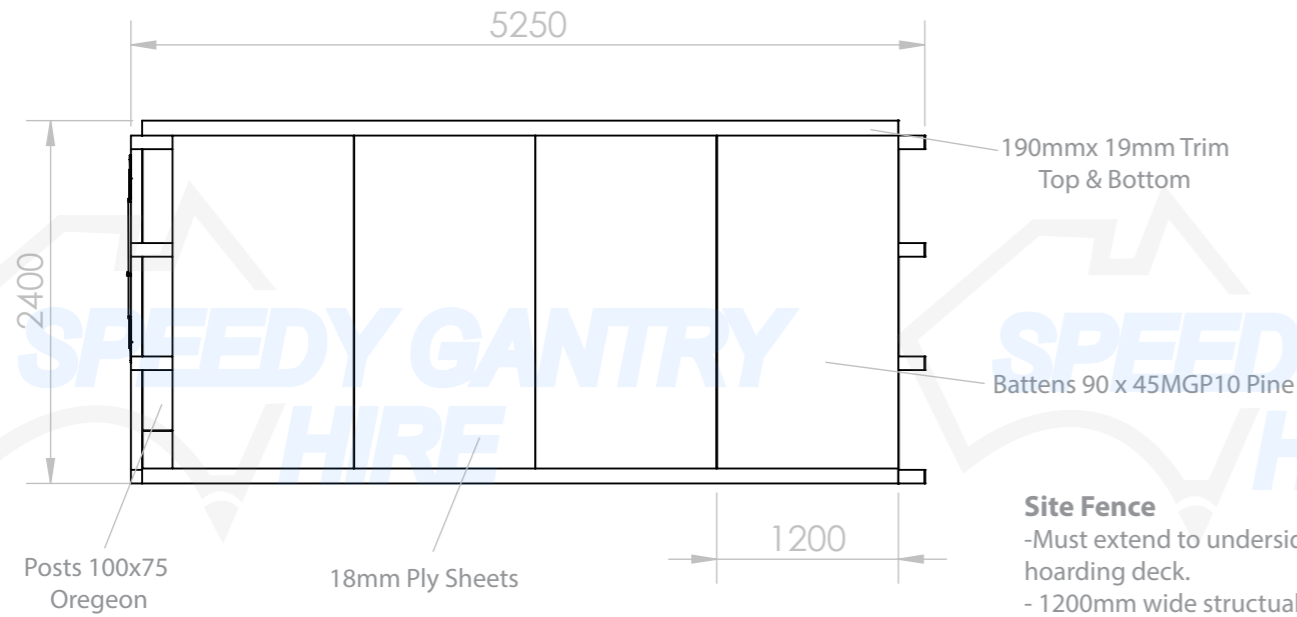

End Section View

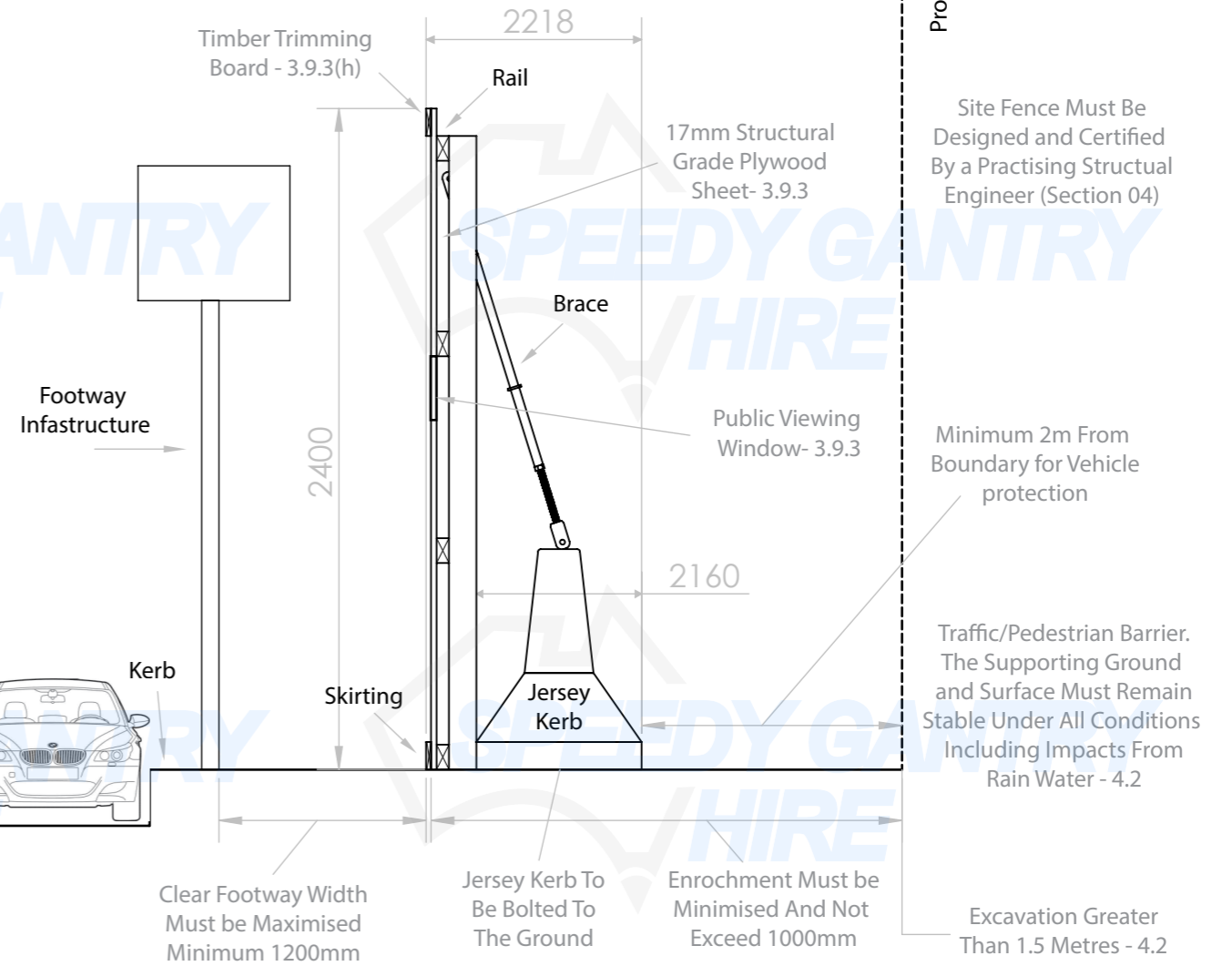

Site Fence

- Must extend to underside of hoarding deck.
- 1200mm wide structural grade plywood sheets of at least 17mm.
- Sheets Must be butt joined & all fixings to be countersunk.
- Incorporate graphics & colours where required.

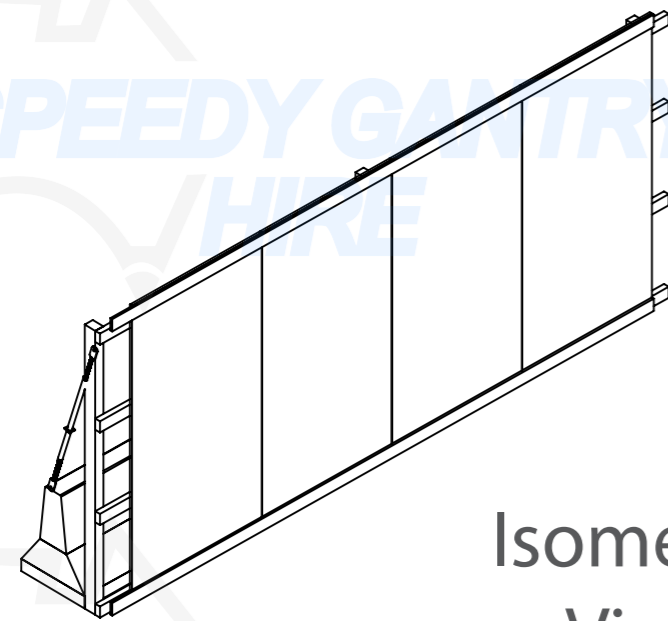
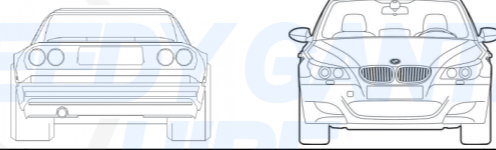

Isometric View

Council Notes:

- Standard: To AS4100-1990
- Steel Grades: U.N.O
Minimum Yield Strength:
Plate 250MPa
RHS & SHS 350MPa Retrofitted Gantry
450MPa New Gantry
CHS 250 MPa
- Unless Noted Otherwise:
(i) Use 6mm Continuous Fillet Weld (CFW)
(ii) Use 10mm Thick Plates
(iii) Use W50X or E48XX Electrodes
(iv) Use M20 8.8/S Bolts
- Protective Treatment:
All Steelwork To Be Painted With An Approved Protection System.

Revision Table:

NO:	DATE:	DESCRIPTION:

Drawing Scale:

Sheet Size: **A3**

This drawing and any information or descriptive material set out on it are the confidential and copyright property of Speedy Gantry Hire. © and MUST NOT BE DISCLOSED, COPIED, LOANED in whole or part or used for any purpose without the written permission of Speedy Gantry Hire.

Document Type:
Company Confidential

Legal Owner:

Speedy Gantry Hire, 95-97 Stanley Road Ingleburn, 1300 Gantry, j@speedygantry.com.au

Builder: Speedy Gantry Hire Pty. Ltd.

Site Address: 95-97 Stanley Road Ingleburn

Drawn by:
Gregory Georgiou

Drawn Date:
30/08/19

Checked/Approved by:
Joshua Foy

Checked/Approved Date:

Associated drawing numbers

Drawing Number: Job Number: Revision: Issue: Sheet:

A 1 1

Property Boundary
Site Fence Must Be Designed and Certified By a Practising Structural Engineer (Section 04)

Minimum 2m From Boundary for Vehicle protection

Traffic/Pedestrian Barrier. The Supporting Ground and Surface Must Remain Stable Under All Conditions Including Impacts From Rain Water - 4.2

Excavation Greater Than 1.5 Metres - 4.2

Clear Footway Width Must be Maximised Minimum 1200mm

Jersey Kerb To Be Bolted To The Ground

Enroachment Must be Minimised And Not Exceed 1000mm